

RoboRack Half-Rack Cases from Gemstar offer MIL-STD durability and airtight protection for the most sensitive electronic components. Part of our Stronghold[®] line, these cases feature rotationally-molded double walls and thick corners for rugged, versatile, and dependable protection.

Standard Features

- Rotationally molded, double-walled durability
- Watertight, airtight and dust-proof with automatic pressure relief valve
- Meets or exceeds MIL-STD 810G and meets military LLRC standards*
- Recessed, heavy-duty black stainless steel hardware
- Field serviceable hardware
- Spring-loaded handles
- Tongue & groove construction with gasket
- Interlocking, stackable design
- Fully removable lids that hang on the sides
- Edge wheels and an extendable pull handle
- Guaranteed Performance*

* See website for guarantee details, complete certifications and test procedures.

Standard Models

- SR1612-7U18

Standard and Custom Options

- Offering a robust selection of custom features, colors, and sizes. For more information visit Gemstarmfg.com, or contact your local Distributor or Sales Manager.

Standard Color Options**



** Colors are approximate and are for visual purposes only.

SR1612-7U18 Top Profile

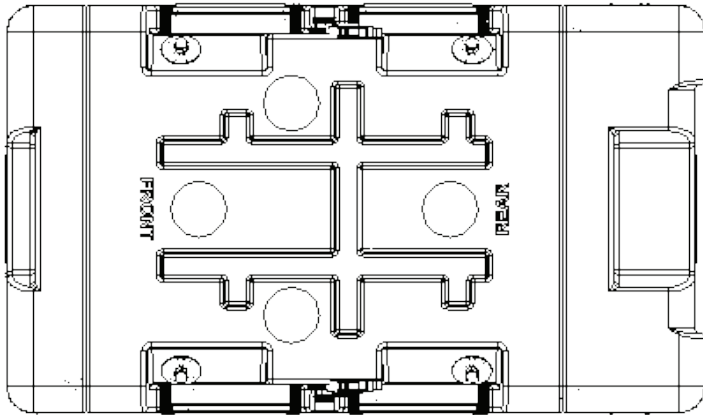

MODEL NUMBER KEY

SR1612-7U18

Height ————
Width ————
Rack Depth ————
Rack Unit ————
Model numbers refer to interior dimensions

SR1612-7U18 Side and End Profile

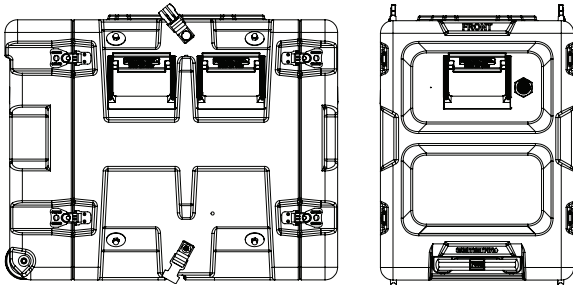

Nominal INT Dimension 23.5"L x 12.1"W x 16"H
597L x 307W x 406H mm

Front Lid Depth 1.75"
44 mm

Rear Lid Depth 3.75"
95 mm

Nominal EXT Dimension 27"L x 15.4"W x 20.7"H
696L x 391W x 526H

Rack Unit Information 7

Rack EXT Dimensions 18"L x 11.1"W x 15.3"H
457L x 282 W x 389H mm

Rack INT Dimensions 17.7"L x 9.5"W x 12.3"H
450L x 241W x 312H mm

Approx. Weight 37 lbs
16.8 kg

Features

- Removable lids
- Spring-Loaded ABS Handles (SS optional)
- PRV

SR1612-7U18 Rack

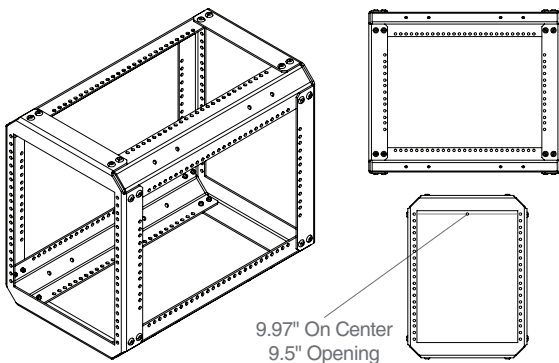

7U Rack

Light weight aluminum rack